

Luminaire Pushwire Connector

2 - pole

P02 - 2 series



- Comply with IEC/EN60998-2-2
- Pushwire "Quick-Connection"
- Easy mounting (with 'fixing - snaps')
- Ready for use with 'Cable - Clamps' (our P02-SR1) for 'strain - relief '*

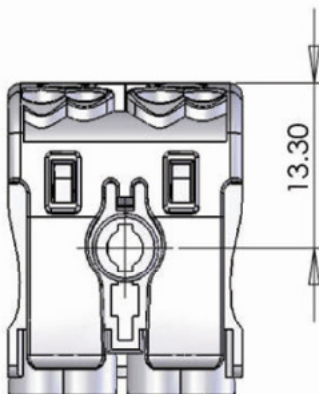
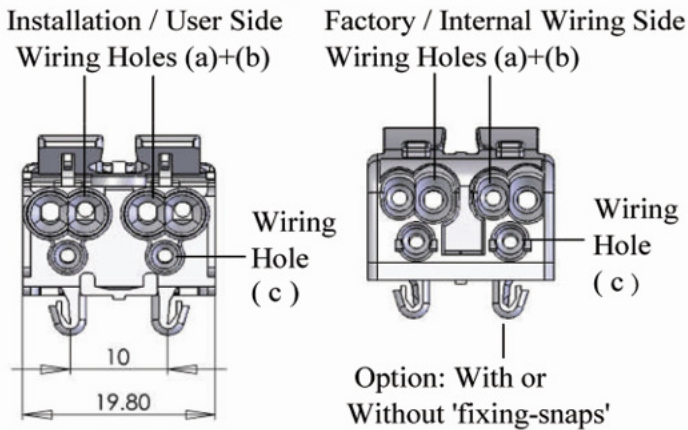
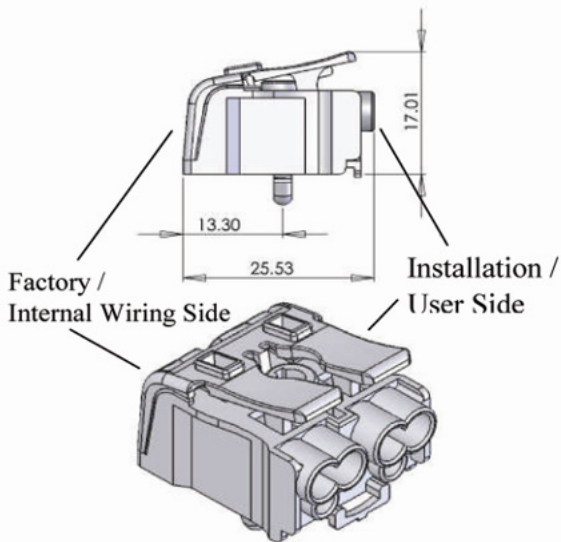
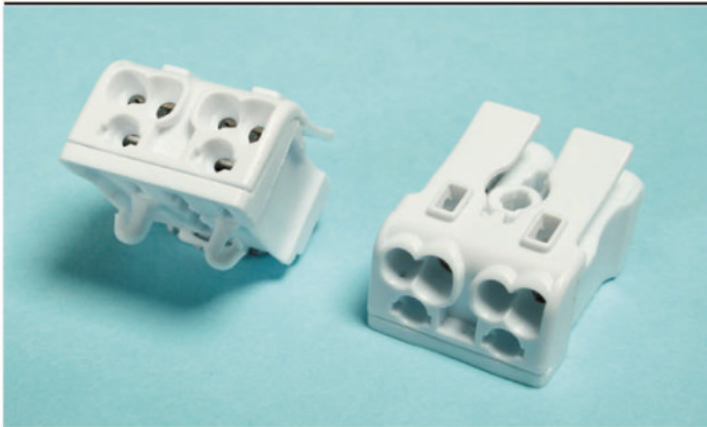

Specification

Housing : Polyamide 66

Metal Part : Plated Brass / Steel spring

Voltage (V) 450

Ampere (A) 10 (for operation)

Wiring Capacity (mm²) :	Wiring Holes (a) + (b)	Wiring Hole (c)
Installation / User-side (with press-release button)	0.5 - 2.5	0.5 - 0.75
Factory / Internal - side (without press-release button)	0.5 - 1.5	0.5 - 0.75
	solid only	solid only

Packing Details

1000 pcs per exp ctn

Product Code

P02 - 2_/9

- blank : No fixing-snaps
- J : With fixing-snaps

* Please refer to P02-05. for details about the cable-clamp.

